



Contact our sales office for delivery dates and prices as this is a special model.

SP112X-012E
P: PZ

 **P.G.Information** (Specialized Product)

Power Clamp Cylinder : $\phi 25$

CKZT25-* -DC*

SMC CORPORATION
4-14-1, SOTO-KANDA,
CHIYODA-KU,
TOKYO 101-0021, JAPAN
URL <http://www.smcworld.com>

■ Features:

- * Force amplification with a toggle system/
Max. clamp moment: 33Nm (Supply pressure: 0.5MPa)
- * The self lock functions in case of air exhaust.
- * Spatter proof construction

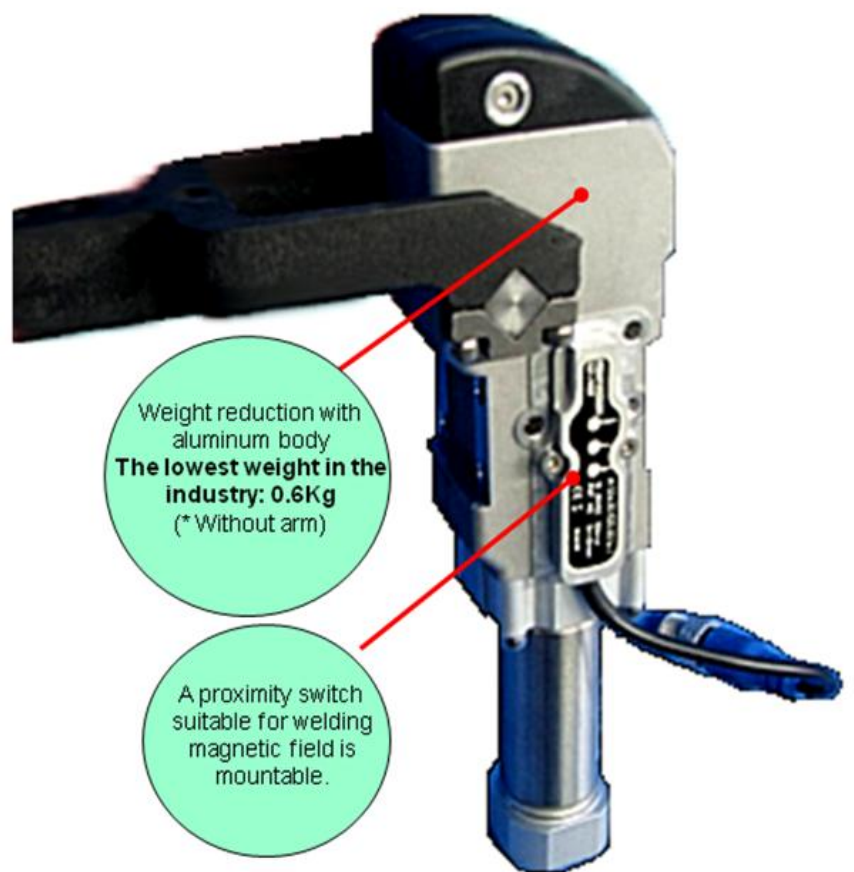
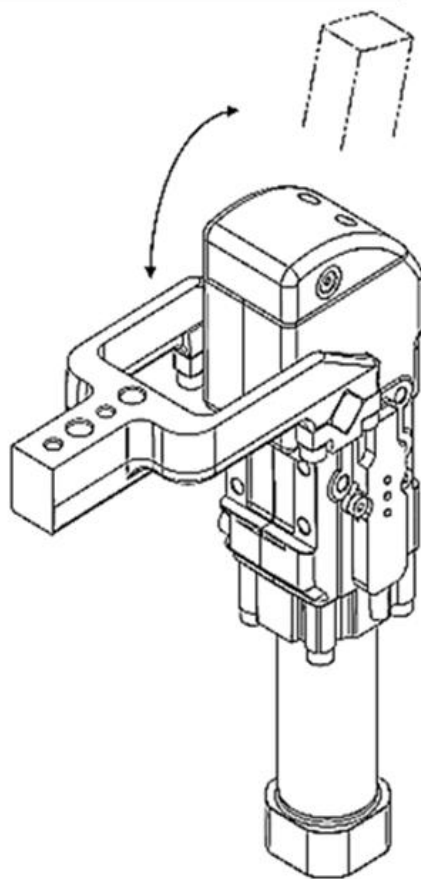

■ Specifications

Specifications [Clamp Cylinder]

Bore size	φ25mm
Arm opening angl	105°
Cushion	Unclamping side rubber bumper
Proof pressure	1.2MPa
Max.operating pressure	0.8MPa
Min. operating pressure	0.3MPa
Operating temperature range	-10~60°(No freezing)
Max.Clamping moment (Supply pressure: 0.5MPa)	33N·m
Allowable lock moment	75N·m
Min.operating time	1sec.to clamp,1sec.to unclamp
Weight	0.6Kg(Without Arm)

Specifications[Proximity switch]

Maker	SENSTRONIC
Operating range	1.8mm
Power supply voltage	10 to 30V DC
Output	N.O. , PNP
Continuous load current	100mA
Enclosure	IP67
Housing material	Aluminum alloy
Output display	Clamp : Red, Unclamp : Yellow
Voltage display	Green

Wiring diagram

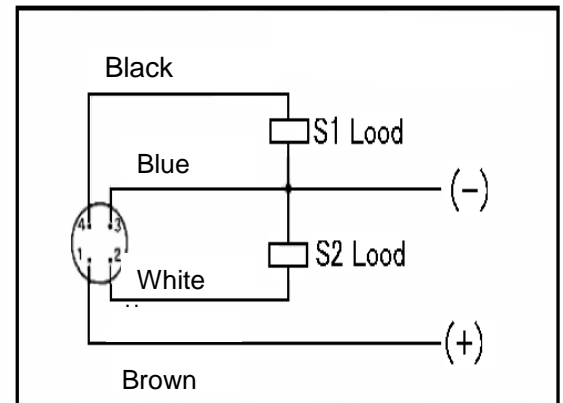

■ How to Order

Clamp Cylinder (Without Arm)

CKZT 25 - 105 - DCL781EL

Bore size: 25, φ 25

Special Product Number: DCL781EL

Arm opening angl
 ※The special product numbers in the following table are applied to various arm openings.

Model	Arm opening angl
CKZT25-105-DCL781EL	105°
CKZT25-90-DCN7018N	90°
CKZT25-45-DCN7017N	45°
CKZT25-30-DCN577NN	30°

Clamp arm

CKZ 25 - 42 - A 781EL - R

Bore size: 25, φ 25

Special Product Number: 781EL - R

Arm mounting position: A

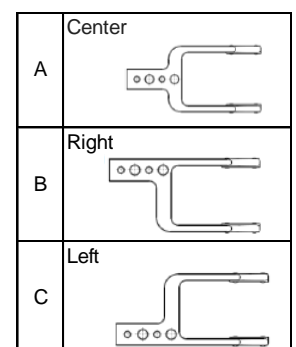

■ Relation between Shim Thickness and Clamping Force

(Note) The self lock does not function when a shim, which is beyond the peak clamp force position in the graph, is inserted.

For insertion of the shim, consider the safety margin for the thickness.

* The arm length L indicates the distance between the clamp arm rotating shaft to the clamping position.

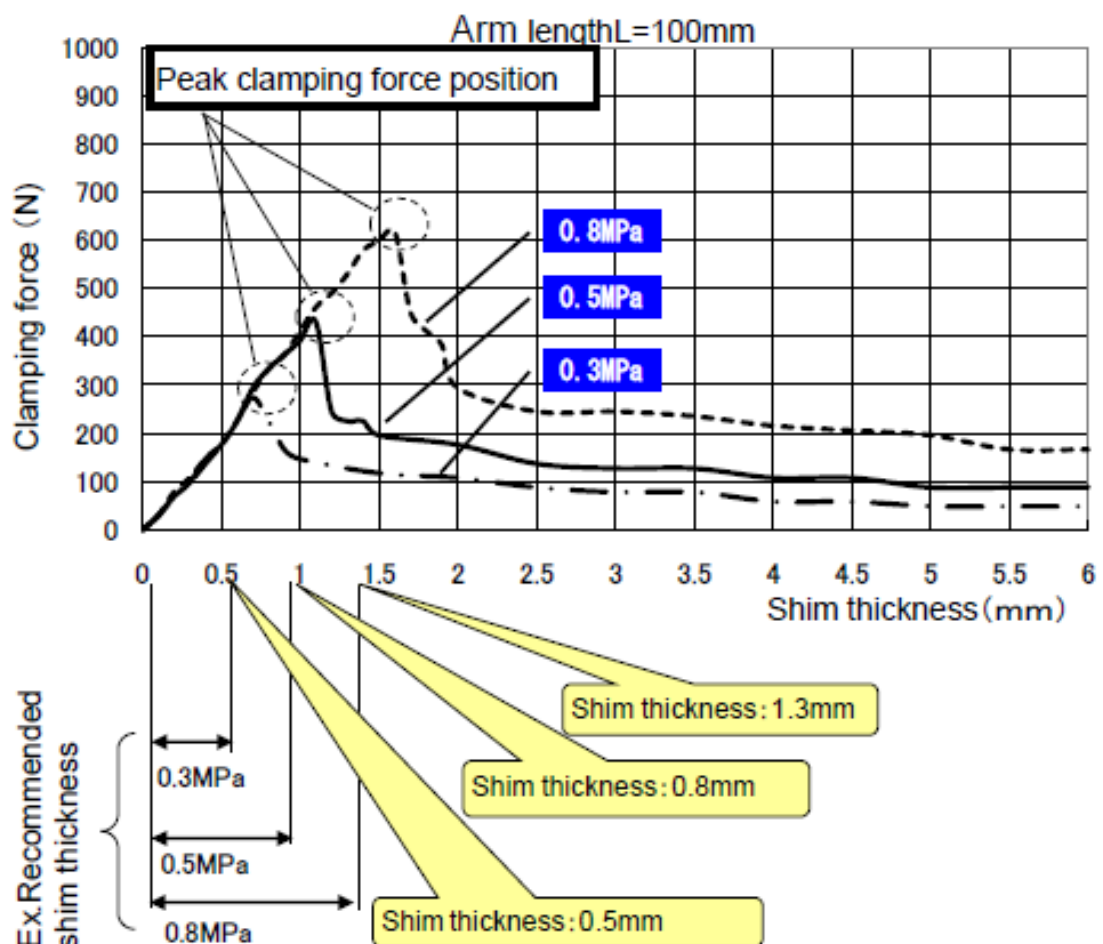
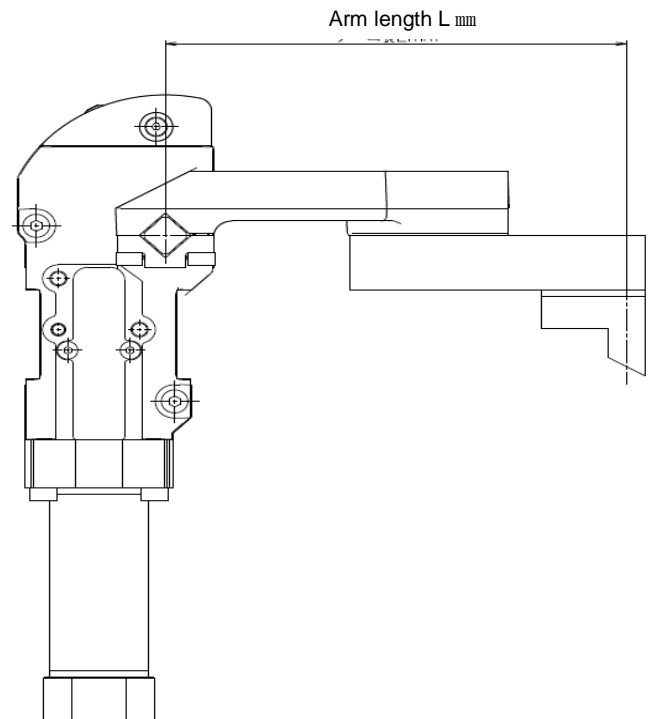

■ Allowable Clamp Arm End Load

Refer to the following figure regarding weight of parts mounted on the clamp arm.

(Note 1) This weight does not include that of the clamp arm.

(Note 2) This weight is an allowable value under the following operating conditions.

* Unclamp --> Clamp: 1 sec. or more

* Unclamp --> Clamp: 1 sec. or more

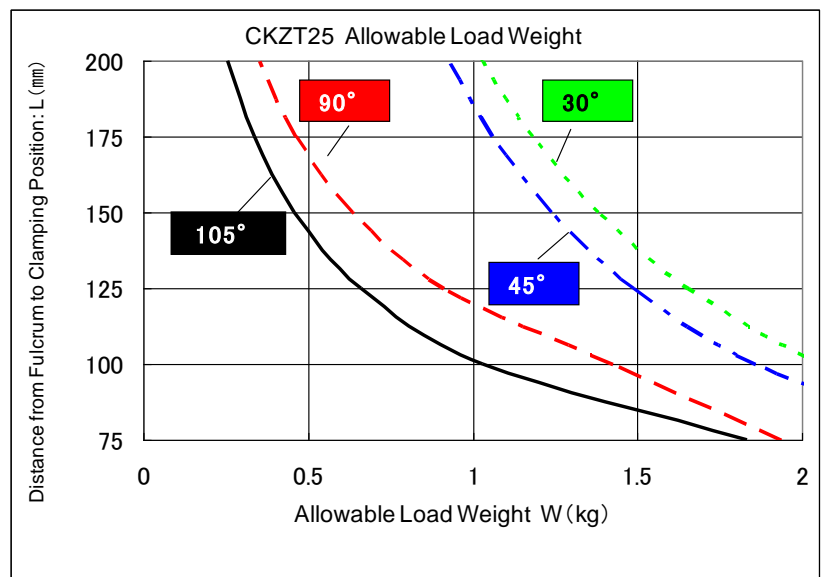
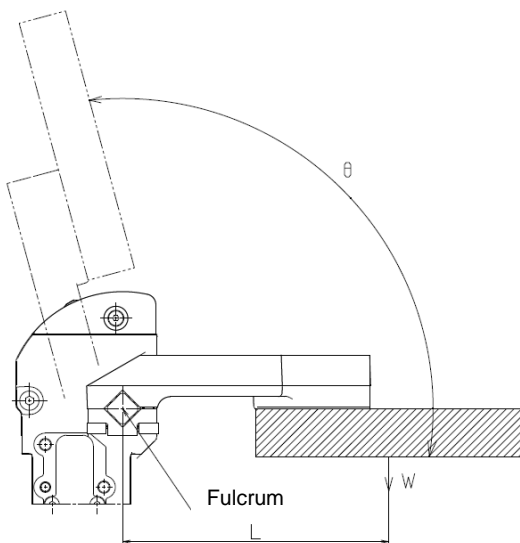

Allowable Lock Moment

Unit: N·m

Allowable Lock Moment
75

* The moment at which the clamp arm is locked in a clamped state and exhausting air

Max.Clamping moment

Unit: N·m

Max.Clamping moment					
0.3MPa	0.4MPa	0.5MPa	0.6MPa	0.7MPa	0.8MPa
20	26	33	39	46	53

Cylinder stroke

Unit: mm

Cylinder stroke			
30°	45°	90°	105°
18.7	22.9	35.4	39.5

■ Dimensions

[Clamp Cylinder Body Dimensions]

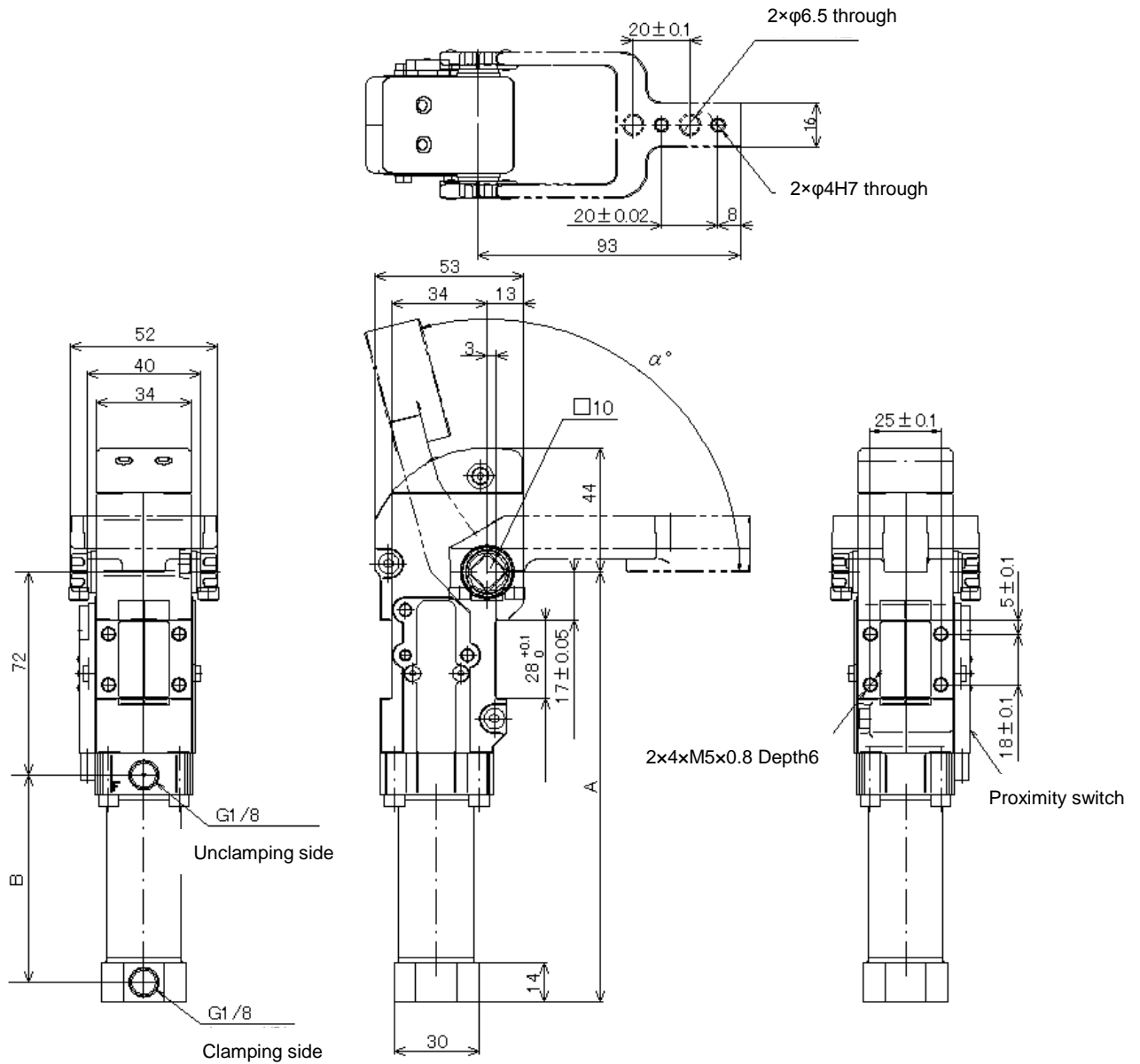

Model	Arm opening angl α°	A	B
CKZT25-105-DCL781EL	105	152.5	73.5
CKZT25-90-DCN7018N	90	148.4	69.4
CKZT25-45-DCN7017N	45	135.9	56.9
CKZT25-30-DCN577NN	30	131.7	52.7

Note: The product body does not include the clamp arm.

[Clamp Cylinder Body Dimensions]

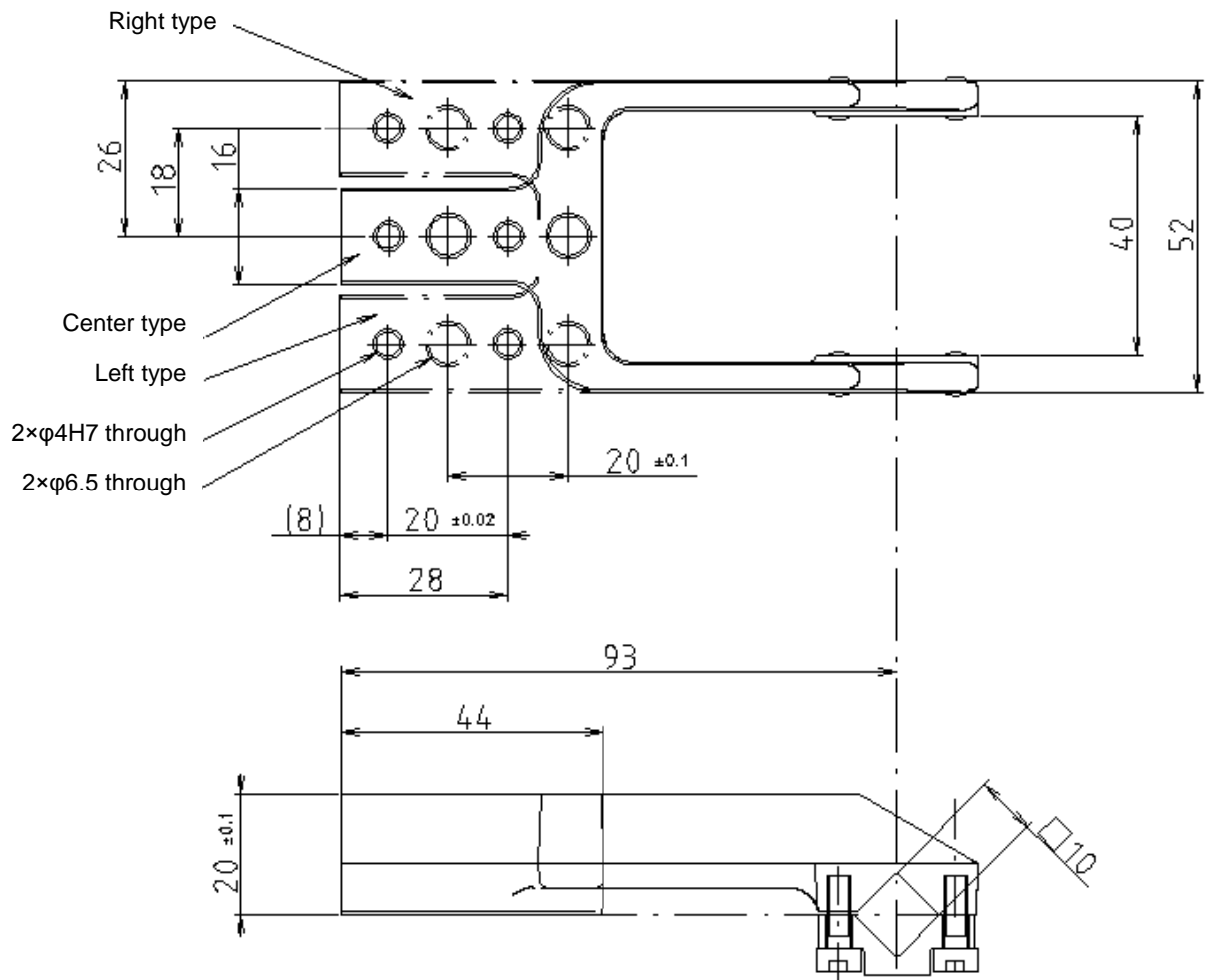

CKZ 25 - 42 * 781EL - R

Model	Arm position	Weight [kg]
CKZ25-42A781EL-R	Center	0.23Kg
CKZ25-42B781EL-R	Right	0.23Kg
CKZ25-42C781EL-R	Left	0.23Kg



Caution To ensure the safest possible operation of this product, please be sure to thoroughly read the "Safety Instructions" in our "Best Pneumatics" catalog before use.